

Material Requirements Worksheet

VERSA-LOK Units

Area of Wall (SF) x 1.5 units/SF = # Units

_____ SF X 1.5 = _____ Units

Number of VERSA-LOK Pins

Units x 2 pins/unit = # Pins

_____ Units x 2 = _____ Pins

Number of VERSA-LOK C Caps

Total Linear Foot of Wall (LF) x .75 = # C Caps

_____ LF x .75 = _____ C Caps

VERSA-LOK Concrete Adhesive

11 oz. Tube: _____ LF ÷ 14 LF/tube = _____ Units

Additional caps may be needed for special splits and cuts.
No pins needed for bottom course.



Copyright 2010, R.I. Lampus Co.



816 R.I. Lampus Avenue, P.O. Box 167
Springdale, PA 15144
Phone: 412.362.3800 • Fax: 724.274.2452
www.lampus.com



INSTRUCTION AND ESTIMATING GUIDE

Installation of the Versa-Lok System is quick and easy:

Proper preparation of the base is the most important procedure in the construction of the wall.

Begin by excavating a trench 24" wide by 6" to 18" deep depending on the wall height. Make sure the bottom of the trench is well compacted. Place sand/gravel base material and compact. The base is now ready for laying the first course of Versa-Lok.

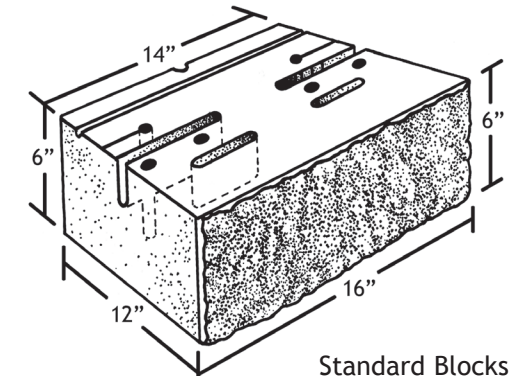

Standard Blocks

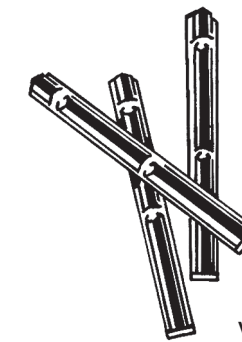
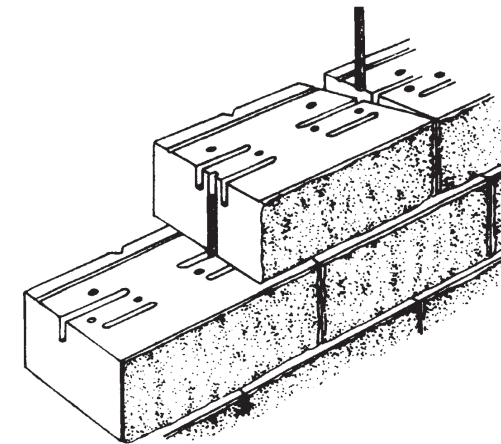

Versa-Tuff Pins

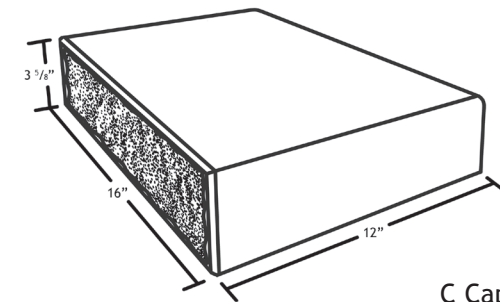

C Cap



Using a string line at the back of the unit to maintain alignment, place the units side by side on the base and level each in both directions. Corners should be laid first. Place backfill and compact. Clean excess fill from the top of the units and place the second course of Versa-Lok. The Versa Tuff pins should be inserted in the holes and extend into the bottom unit. It may be necessary to use a hammer to seat the pin properly. Backfill as you go. A 12" thicker layer of granular fill behind will insure drainage. That's all there is to it. Continue setting units to the height of wall required. The pins will automatically set the succeeding course back at the proper cant into the fill.

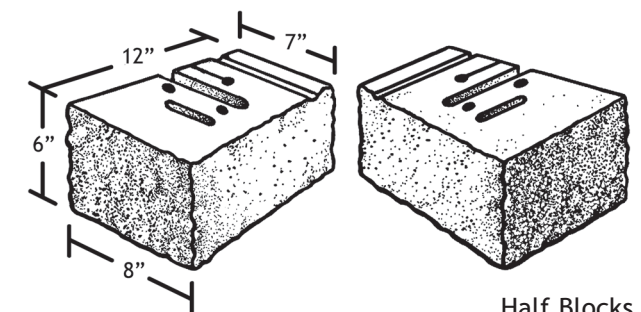

Half Blocks

Building Inside & Outside Corners

The construction of a corner will depend on if the wall is started at the corner or building toward the corner. If at all possible start the wall at the corner and work out from there.

The construction drawing shows how to install corners in a 3/4 bond arrangement. Because the Versa-Lok is a solid unit the installer is allowed to make custom size pieces if a half bond is required. The Versa-Lok units pin from hole to slot, this allows the bond to vary.

To build an outside corner, start with a 1/2 unit. These can be split with a hammer and chisel or ordered from your supplier. Lay full Versa-Lok units to either side of this corner unit. On the second course the 1/2 unit will be laid in the opposite direction, this will establish a stagger bond to the wall. Continue alternating this corner unit as the wall goes up. Please note: the corner unit does not get pinned into the lower course. If a 1/2 bond is required, the units next to the 8" face of the half unit will need to be custom sized on the job site. This can easily be done by cutting them with a masonry saw.

The inside corner is constructed the same way as the outside corner. The only difference would be the direction the face is laid.

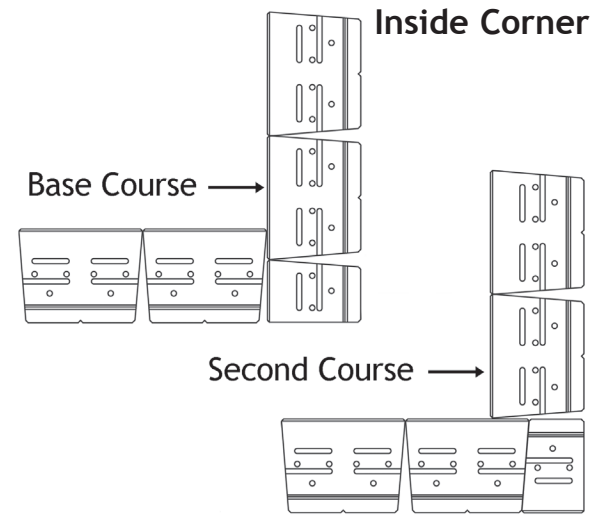
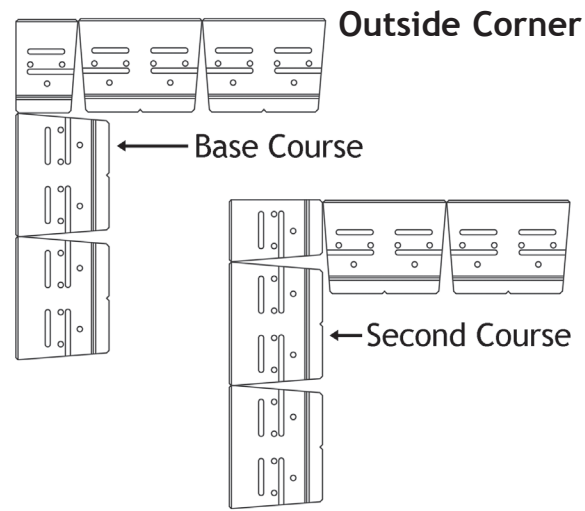

WALL HEIGHT	COURSE	BOTTOM COURSE O/S RADIUS	MINIMUM O/S RAD FOR TOP
4 FT.	8	8' - 6 1/4"	8' - 1"
3 FT.	7	8' - 5 1/2"	8' - 1"
2 FT.	5	8' 4"	8' - 1"
1 FT.	3	8' - 2 1/2"	8' - 1"
BOTTOM	1	8' - 1"	8' - 1"

EXAMPLE: 3 FT. WALL = 6 COURSES
1 SETBACK = 3/4"
5 SETBACKS = 3 3/4"
BOTTOM O/S RADIUS = 8' - 4 3/4"

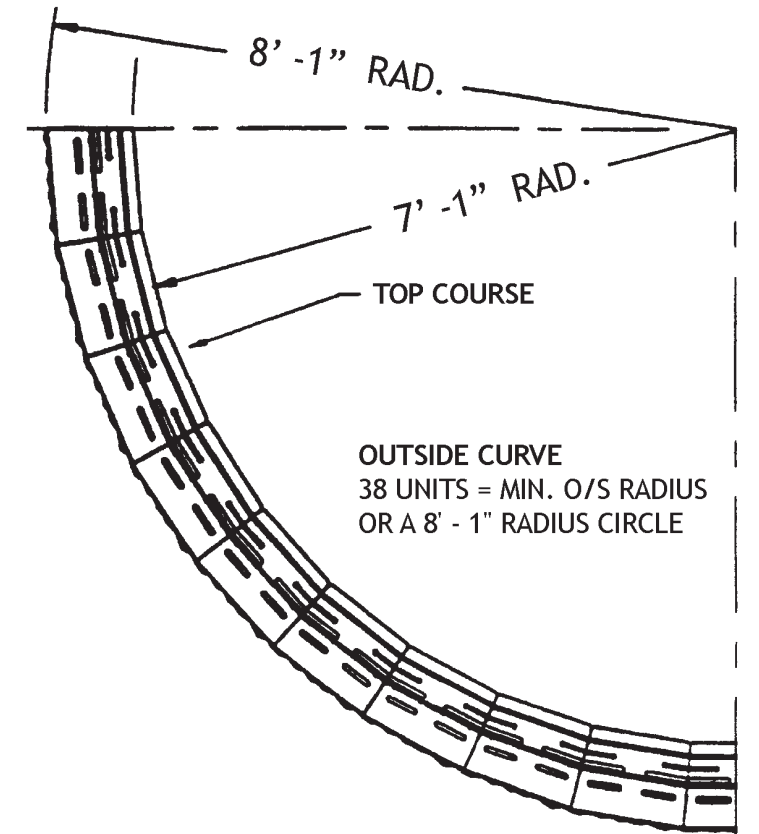

Installation Procedure

1. Stake the center of the curve.
2. Excavate for the sand & gravel base.
3. Place first unit on radius.
4. Swing layout line from center.
5. Place second unit adjacent to first.
6. Continue until curve is completed.
7. Stagger subsequent courses.
8. Adjust units for proper fit.
9. Automatic setback is 3/4 in. per course.
10. Continue until desired height is achieved.

* Minimum radius is achieved at the top course when the bottom course is started at the proper radius from the table.

WALL HEIGHT	COURSE	BOTTOM COURSE I/S RADIUS	I/S RAD FOR TOP
4 FT.	8	5' - 5 3/4"	5' - 11"
3 FT.	7	5' - 6 1/2"	5' - 11"
2 FT.	5	5' - 7 1/4"	5' - 11"
1 FT.	3	5' - 8 3/4"	5' - 11"
BOTTOM	1	5' - 9 1/2"	5' - 11"

EXAMPLE: 3 FT. WALL = 6 COURSES
1 SETBACK = 3/4"
5 SETBACKS = 3 3/4"
BOTTOM I/S RADIUS = 5' - 7 1/4"

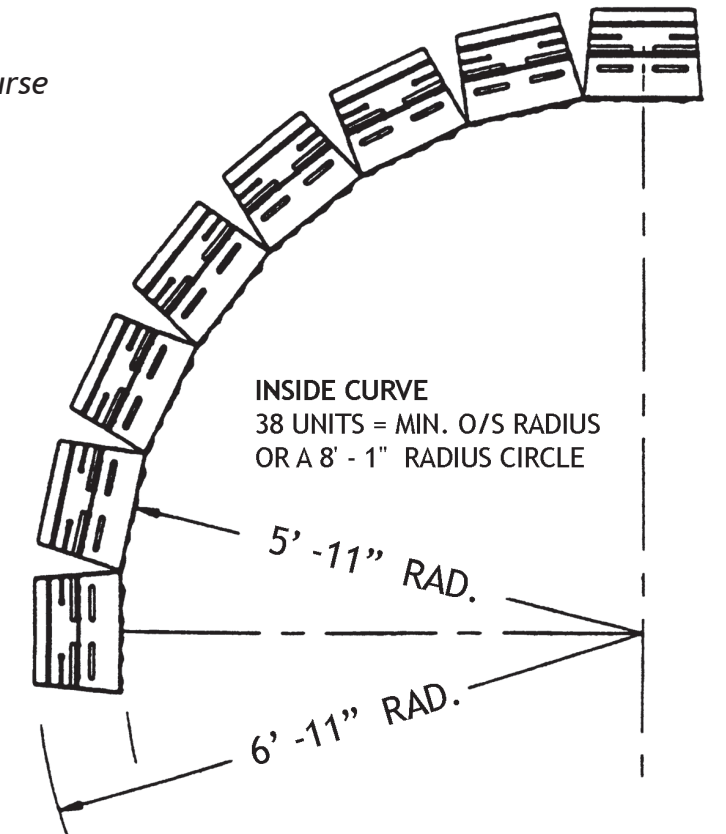

Stair Riser Detail

Base Pedestal Method (Recommended)

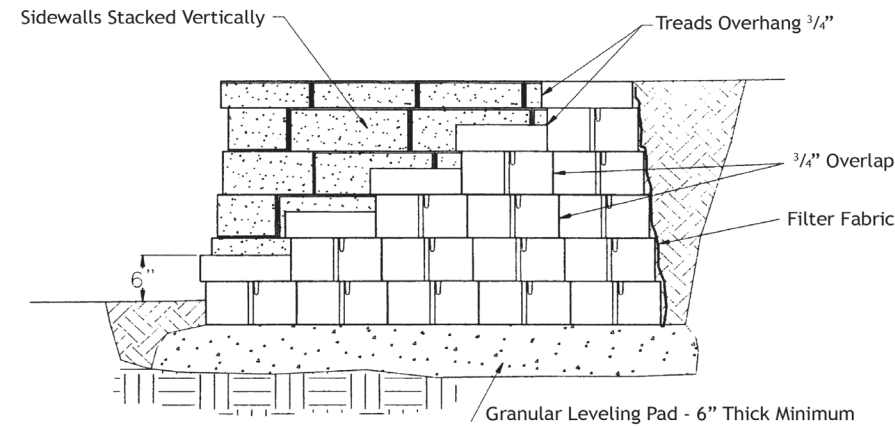

STAIR NOTES:

1. Use the same leveling pad material for stair pedestal as retaining wall.
2. Construct the stair risers first, install caps for treads second and then install the sidewalls last.
3. Do Not pin stair units.
4. Construct the base pedestal in 4 to 5 riser increments.
5. The sidewalls will be stacked vertically without pinning.
6. Wrap the pedestal in filter fabric.
7. See the Versa-Lok Tech Bulletin 2 for construction details.

Note: Walls over 4 feet must be designed by a qualified engineer.